

- Spectra
- Evolution
- SunStrip
- FireFly

FRC LED LIGHTING
THE BRIGHTEST BEAMS ON EARTH.

EVOLUTION

ULTRABRIGHT LED SERIES



Evolution Lampheads Generate 15,000 Lumens of UltraBright White LED Light Directly on the Scene

- *Unique LED Array design provides more light in a compact lamphead.*
- *Brighter Light - more than 15,000 lumens of ultra bright LED light*
- *Whiter light, closer to natural sunlight*
- *Uniform high quality white light with the widest light pattern*
- *Long operating hours – rated at 50,000 hours*
- *Instant-On at Full Intensity*
- *Parabolic Reflector designed to direct all the light onto the scene*
- *Five Year LED lighting warranty*

FRC LED

Brighter. Whiter. Better.

1.800.645.0074 • www.firereseach.com



EVOLUTION

ULTRABRIGHT LED SERIES

THE LIGHTS THAT TURN DARKNESS INTO DAYLIGHT



FRC
FIRE RESEARCH CORP.

- UltraBright 15,000 lumens light output, 12,000 lumens for recessed mount
- Full brightness at power on - Instant restarts - No warm up
- Can be used with all FRC telescopic poles, tripods, fixed non-telescopic & brow mounts
- Lamphood can be used with 12 or 24 volt DC systems (13/6.5 amps)

dimensions :

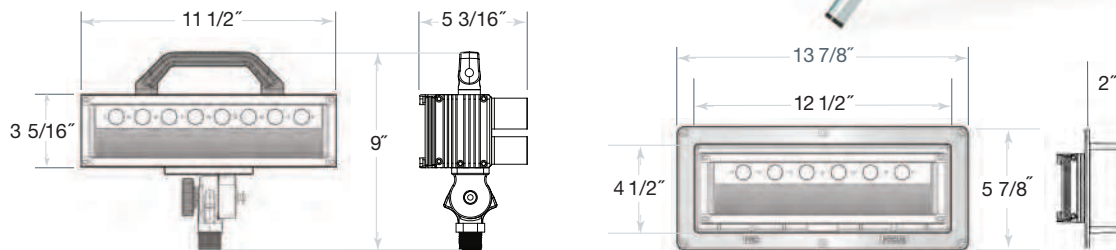

ordering:

Part No	Description / Specs		
FCA210-V12	Recessed Mount (12,000 lumens, 12/24 VDC)	FCA570-V15	Fixed Top Mount
FCA100-V15	Standard Lamphood	FCA580-V15	Fixed Side Mount
FCA300-V15	Under Aerial Mount	FCA600-V15	Tripod Telescopic Pole, Standard
FCA510-V15	Top Mount Pull Up Telescopic Pole	FCA642-V15	Tripod Telescopic Pole, Small
FCA510C-V15	Top Mount Pull Up Telescopic Pole, Square Flange	FCA656-V15	Tripod Telescopic Pole, Medium
FCA510E-V15	Top Mount Pull Up Telescopic Pole, 3" Square Flange	FCA700-V15	Portable
FCA512-V15	Top Mount Push Up Telescopic Pole	FCA800-V15	Brow Contour Mount
FCA530-V15	Side Mount Push Up Telescopic Pole	FCA830-V15	Brow Universal Mount
FCA540-v15	Side Mount Pull Up Telescopic Pole	FCA850-V15	Brow Flat Mount
FCA542-V15	Side Mount Pull Up Telescopic Pole		

THE BRIGHTEST BEAMS ON EARTH.

• Spectra • Evolution • SunStrip • FireFly

FIREFLY

COMPARTMENT MOUNTED LED LIGHT



shown actual compact size of just
2 5/8" in diameter and 3/4" thick.

***FIREFLY brings UltraBright White LED Light
to all compartments that exceeds
other fixtures.***

The LEDs are housed in a waterproof, anodized aluminum case, built tough for all environments

- **Four (4) white, long life LEDs**
- **UltraBright 650 lumens light output**
- **Lights up entire compartment**
- **Mounts in any orientation and on any flat surface**
- **12 VDC-0.8 amps / 24 VDC-0.4 amps**
- **Low power saves energy**
- **Instant on at full intensity**
- **Completely sealed electronics, can be used for ground or surface lighting**
- **Small & compact**
- **Five year LED lighting warranty**

ordering:

- LED100-Q01 firefly compartment light (with glare reducing lens)
- LED110-Q01 firefly work light

FRC LED

Brighter. Whiter. Better.

1.800.645.0074 • www.fireresearch.com



THE BRIGHTEST BEAMS ON EARTH.

• Spectra • Evolution • SunStrip • FireFly

SPECTRA 900

ULTRA BRIGHT LED SERIES

ACTUAL SCENE COMPARISON



FRC **SPECTRA 900** LED LIGHTING

QUARTZ HALOGEN LIGHTING

**DELIVERS
4600 LUMENS OF LIGHT**

THE BRIGHTEST SCENE LIGHTING FOR EMERGENCY RESPONSE VEHICLES

Innovative lens that focuses 100% of the ultrabright LED light directly where it is needed, on the scene.



- **UltraBright** 4600 lumens light output using 24 white LEDs
- Extremely low profile extends less than 1-3/4" from the panel
- Completely Waterproof even if light is fully submerged
- Easy to install, no panel cut-out needed

dimensions: W 9" x D 1-3/4" x H 6-3/4"

ordering : SPA900-Q65 LED surface mounted in chrome bezel (standard)

option : BLA Black bezel

FRC LED

Brighter. Whiter. Better.

1.800.645.0074

www.fireresearch.com



- Spectra
- Evolution
- SunStrip
- FireFly

FRC LED LIGHTING
THE BRIGHTEST BEAMS ON EARTH.

SPECTRA

ULTRABRIGHT LED SERIES



Spectra Lampheads Generate 20,000 Lumens of UltraBright White LED Light Directly on the Work Area & Scene Beyond

Higher Lumens with Unique cooling fins design



Slimmest lamphead profile

- **The Brightest LED Scene Lights**
- **Whiter Light - closest thing to natural sunlight**
- **Slimmest LED lamphead profile in the industry**
- **Innovative Cooling Fins provide higher efficiency and more lumens**
- **Unique Combination of Flood / Spot LED design**
- **Available on FRC Pole, Brow, Fixed or Surface Mounts**
- **Surface Mount does not require panel cut-out**
- **Instant-On at Full Intensity**
- **Five Year LED lighting warranty**

FRC LED

Brighter. Whiter. Better.



SPECTRA

ULTRABRIGHT LED SERIES

THE LIGHTS THAT TURN DARKNESS INTO DAYLIGHT

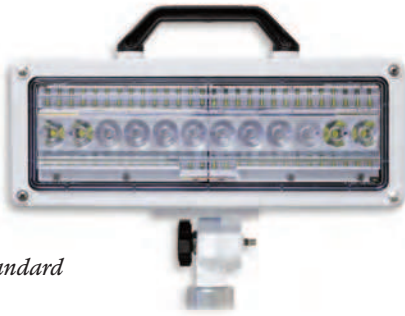

Shown in standard white finish

SPECTRA LED LAMPHEADS

- ★ Available for all FRC telescopic pole, brow, or fixed mounts.
- ★ Brighter light for improved job performance.
- ★ Longer LED life rated at 50,000 hours.
- ★ Choose 15,000 lumens – 12/24 VDC, 13/6.5 amps or 20,000 lumens – 12/24 VDC, 18/9 amps.
- ★ White bezel standard. Chrome or black optional.



Shown in standard chrome finish

SPECTRA SURFACE MOUNT LAMPHEAD

- ★ Surface mount instead of recessed mount makes it easier and faster to install. No panel cut-out is needed.
- ★ Slim body design depth of only 1.8" keeps lamphead closer to vehicle.
- ★ 15,000 lumens – 12/24 VDC, 13/6.5 amps.
- ★ Chrome bezel standard. White or black optional.

UNIQUE SPECTRA FLOOD / SPOT LIGHT PATTERN IS PERFECT FOR FIREFIGHTING



Three rows of LEDs with the top and bottom rows designed as flood light to light up the work area. The middle row has focused spot LEDs to provide long distance illumination.

Spectra unique lens design provides a smooth and uniform flood and spot combination bringing firefighters the widest light pattern for improved work area visibility as well as illuminating objects at a farther distance.

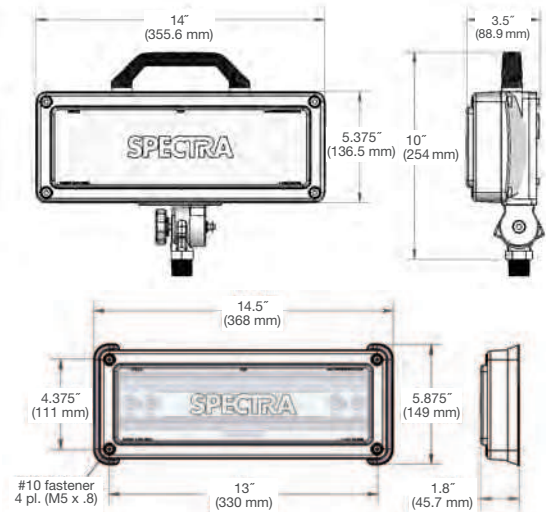

Dimensions:

Pole mount : 14.0" w x 5.375" h x 3.5" d

Surface mount : 14.5" w x 5.875" h x 1.8" d

To order: Indicate series SPA for SPECTRA; the mount type; and lamphead type.
(-Q15 = 15,000 lumens or -Q20 = 20,000 lumens)

THE BRIGHTEST BEAMS ON EARTH.

• Spectra • Evolution • SunStrip • FireFly

SUNSTRIP

ULTRABRIGHT LED SERIES

High Quality UltraBright White LED Light for Compartments, Panels, Under Body Applications Walkways & Stairwells

- **Brightest Strip Light** - more than 300 lumens of actual ultra bright LED light per 18" length
- **Completely waterproof and submersible, great for all applications**
- **LEDs housed in a strong 5/8" diameter Lexan tube**
- **Designed tough to withstand any vehicle vibration**
- **Easy to install**
- **Long LED life. Rated at 50,000 hours**
- **Five year LED lighting warranty**

Direct the Light Where You Want It.

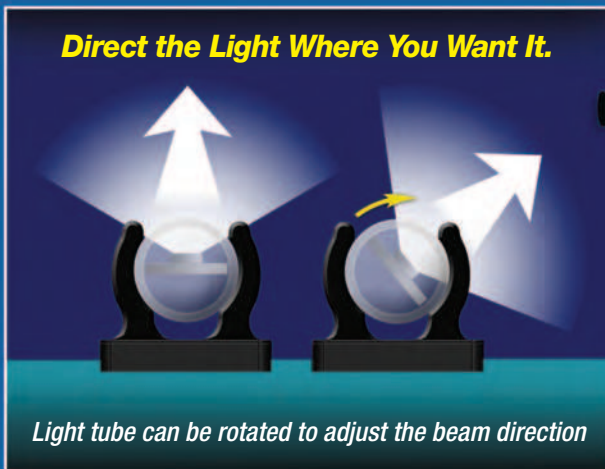

Available in 9" length increments from 9" to 63"



ordering:

Part no.	Tube Length*	Lumens	Current@12V
LED200 - A09	9"	150	0.17 amps
LED200 - A18	18"	300	0.35 amps
LED200 - A27	27"	450	0.52 amps
LED200 - A36	36"	600	0.70 amps
LED200 - A45	45"	750	0.87 amps
LED200 - A54	54"	900	1.05 amps
LED200 - A63	63"	1050	1.22 amps

*Add 2" for end caps & wire clearance • Mounting clips supplied • 24V also available

FRC LED

Brighter. Whiter. Better.

1.800.645.0074 • www.fireresearch.com

